



Quality / Technology / Service / Value

PRESSURE SWITCH FOR WATER SYSTEM APPLICATIONS

RP-80



Product datasheet Characteristics



Applications

Pressure switches for use with water in autoclave systems: firefighting systems, water pumps... The switch ensures automatically the starting and stopping of the electric pump according to the pressure values.

Main

Product name	PELTA D
Product model	RP-80
Maximum pressure range	8 bar (116psi)
Setting range	3.6...8 bar (53...116 psi)
Electrical circuit type	Power circuit
Product Specific Application	Control electrically driven water pumps
Quantity per Set	1
Type of Packing	Individual

Complementary

Pressure sensor type	Electromechanical pressure switch
Controlled fluid	Fresh water -30...125 °C (-22...257 °F)
Adjustable range on rising pressure	3.6...8 Bar (53...116 Psi)
Approximate adjustable differential	3.6...5 Bar (53...73 Psi)
Destruction pressure	20 Bar (290 Psi)
Pressure actuator	Diaphragm between 2 thresholds
Pressure switch type of operation	Regulation
Scale type	Adjustable differential <input type="checkbox"/>
Setting	Internal
Local display	Without
Contacts type and composition	Normally closed and made of copper with Ag-Ni surfacing
Cable entry number	2 x 22.35 mm (0.88 in) cable entries with 0.84 in across flats UL 508
Electrical connection	Screw-clamp terminals 10 AWG Screw-clamp terminals 5.261 mm ²
Fluid connection type	1/4 in BSPP internal (female) thread
Short-circuit protection	20 A cartridge fuse
Materials in contact with fluid	Zinc plated steel or equivalent flange Nitrile (Buna-N) or equivalent rubber diaphragm



Material	Polypropylene Cover Noryl thermoplastic resin or equivalent Cover
Operating position	Any position
Motor power kW	(2.2 KW 3 hp) 230 V AC, 1 phase (1.1 KW 1.5 hp) 115 V AC, 1 phase (1.5 KW 2 hp) 115 V AC, 3 phase (2.2 KW 3 hp) 230 V AC, 3 phase (2.2 KW 1 hp) 460 V AC, 3 phase (0.75 KW 1 hp) 575 V AC, 3 phase
Electrical durability	100000 Cycles 10 cyc/mn
Mechanical durability	300000 Cycles
Terminal block type	4 terminals
Maximum operating rate	10 Cyc/Mn
Net Weight	0.45 kg (1 Lb)
Repeat accuracy	+/-3 %
Terminals description ISO n°1	L2-T2 L1-T1
Maximum Width	70.61 mm (2.78 In)
Maximum Height	71.12 mm (2.80 In)
Maximum Depth	95.5 mm (3.76 In)
Factory modification	-

Environment

Standards	CE
Ambient Air Temperature for Operation	-36...125 °C (-33...257 °F)
Ambient Air Temperature for Storage	-36...125 °C (-33...257 °F)
Protective treatment	None

Ordering and shipping details

Category	PELTA D RP-80 (INDIVIDUAL)
No. of units in pkg.	1 Pcs.
Package weight	0.45 Kg (1 lb)□
Box quantity	48 Pcs.
Box weight	21.36 Kg (47 lb)
Returnability	Yes

Packing Units

Unit Type of Package 1	PCE
Package 1 Height	195 mm (7.68 in)
Package 1 width	94 mm (3.71 in)
Package 1 Length	126mm (4.96 in)



Dimensions

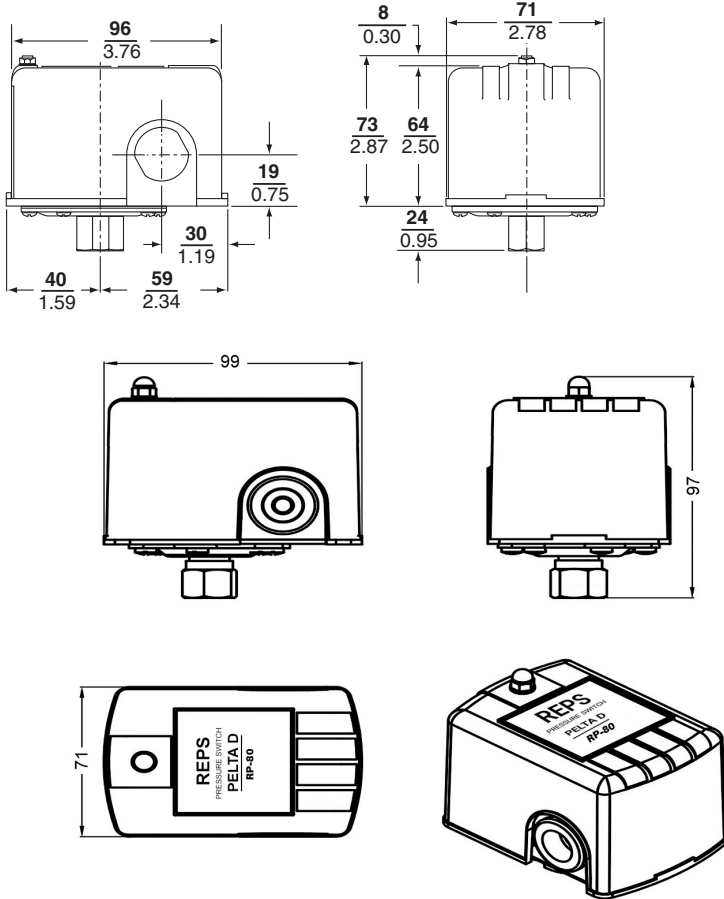

Flange Style

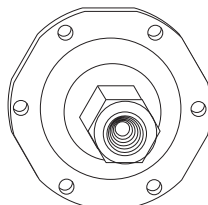

1/4" BSPP internal (female) thread

PRESSURE SWITCH



REPSGLOBALGROUP

Email: Info@repsGG.com

<https://repsGG.com>

